

www.1999.gr

MAZDA MX-5 MIATA 2006-2008

1 Disconnect the negative battery terminal to prevent an accidental short circuit.

2 Unclip panel below steering column and remove. (Figure A)

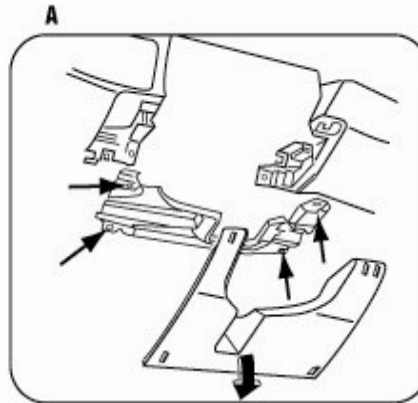

3 Remove (4) Phillips screws from metal brace below steering column and remove. (Figure A)

4 Looking at the side of the radio/climate control panel from underneath the steering column opening, remove (1) 10mm bolt from the side of the radio chassis. (Figure B)

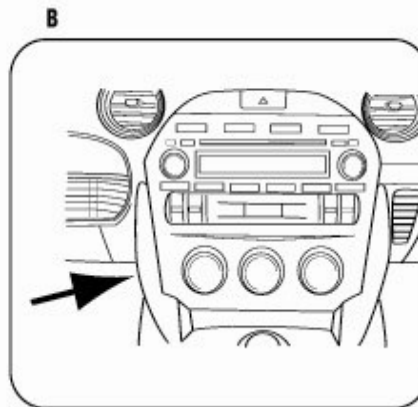

5 Carefully remove the side panels from each side of the radio/climate control panel by pulling straight back towards the rear of the car. (Figure C)

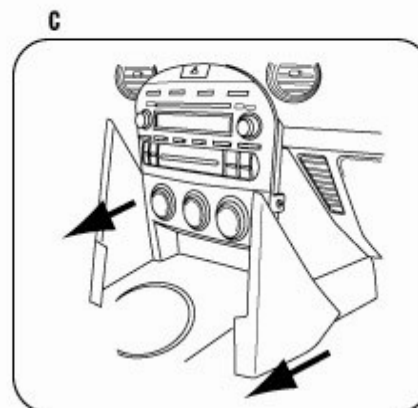

www.1999.gr

MAZDA MX-5 MIATA 2006-2008

- 6** Remove (2) Phillips screws, (1) on each side, from the side of the radio/climate control panel. (Figure D)

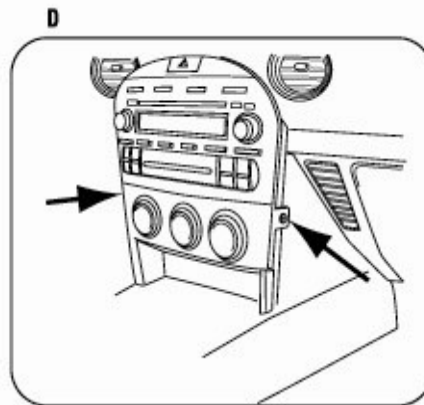

- 7** Pull radio/climate control panel out, disconnect plugs and remove. (Figure E)

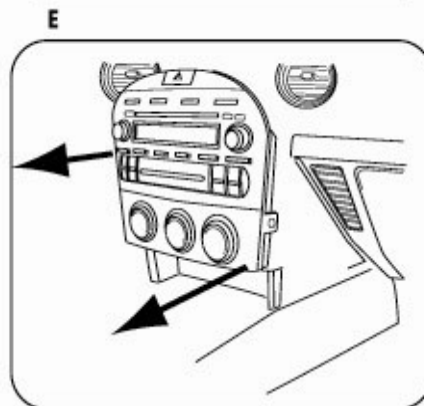

- 8** Turn the radio/climate control panel over and remove the (4) screws that hold the climate control to the bezel, then remove the climate control. (Figure F)

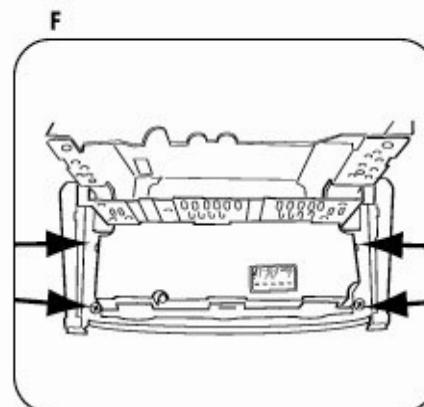

www.1999.gr

DIN HEAD UNIT PROVISION

- 1 Turn over the 99-7506 housing, take the climate control and screws removed from the factory panel and attach the climate control to the kit housing using the factory screws. (Figure A)

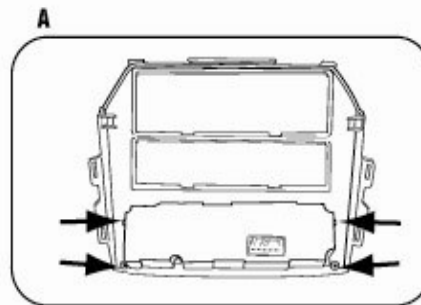

- 2 Slide the pocket into the bottom section of the kit housing. (Figure B)

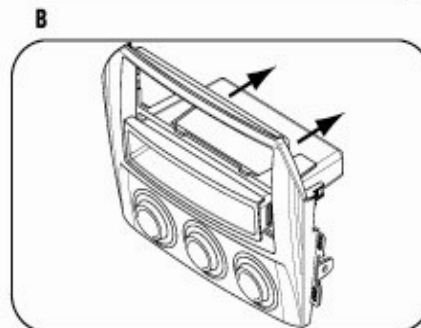

- 3 Slide the DIN cage into the Radio Housing and secure by bending the metal locking tabs down. (Figure C)

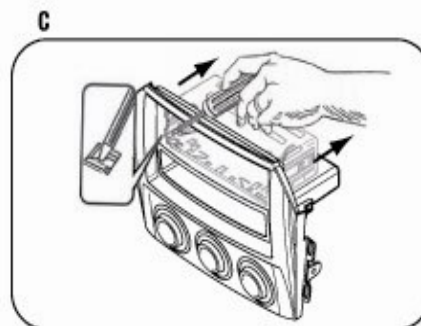

- 4 Slide the aftermarket head unit into the cage and secure. (Figure D)

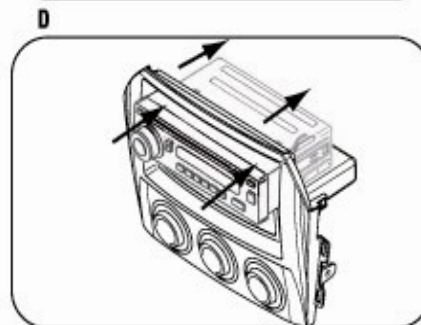

3

WWW.1999.gr

ISO DIN HEAD UNIT PROVISION

- 1 Turn over the 99-7506 housing, take the climate control and screws removed from the factory panel and attach the climate control to the kit housing using the factory screws. (Figure A)

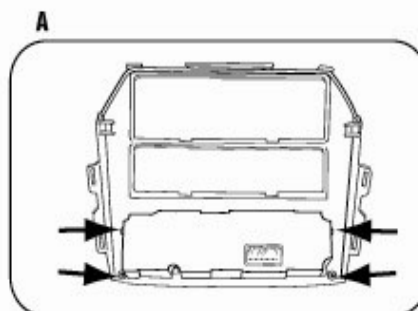

- 2 Slide the pocket into the bottom section of the kit housing. (Figure B)

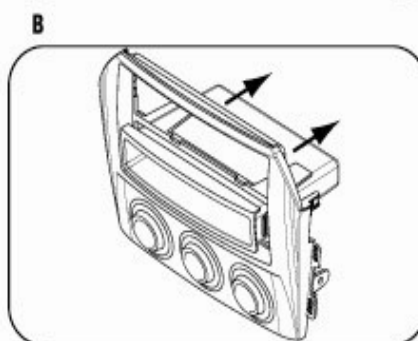

- 3 Mount the ISO Brackets to the head unit with the screws supplied with the unit. (Figure C)

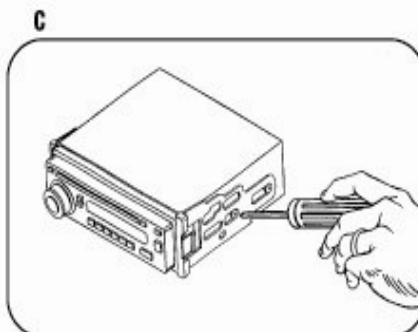

- 4 Slide the head unit into the radio opening until the side clips engage. (Figure D)

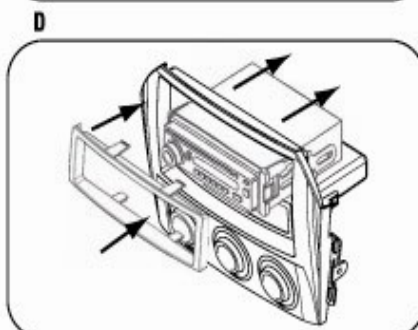

- 5 Snap the Trim plate into the Radio Housing. (Figure D)

www.1999.gr

DOUBLE DIN HEAD UNIT PROVISION

- 1 Turn over the 99-7506 housing, take the climate control and screws removed from the factory panel and attach the climate control to the kit housing using the factory screws. (Figure A)
- 2 Cut the rib in the middle of the 99-7506 housing to make room for the DDIN brackets. (Figure A)

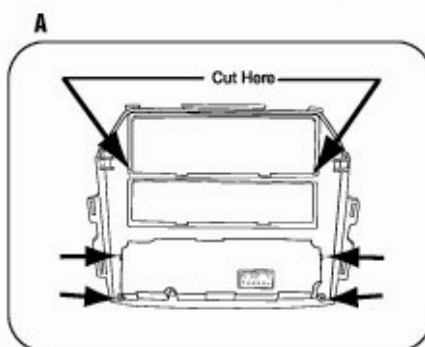

- 3 Slide the appropriate DDIN bracket into the kit housing. (Figure B)

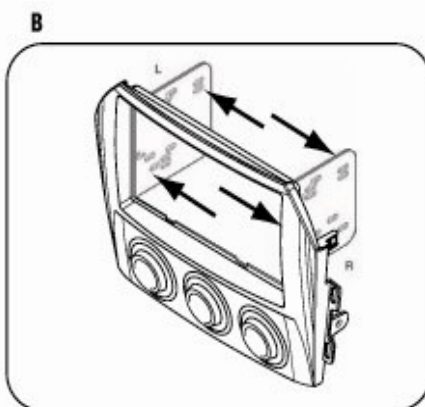

- 4 Slide the DDIN radio unit into DDIN brackets and secure the unit to the kit using the screws supplied with the head unit. (Figure C)

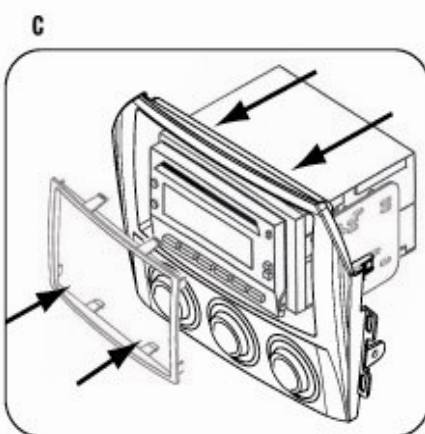

- 5 Snap the DDIN trim plate into the front of the kit housing. (Figure C)

